

These instructions provide the user with information for installation of Swagelok® jacketed and insulated tubing. For additional information, see the product literature.

 **Caution**
All installations must be done in accordance with applicable local codes.

Jacketed and Bundled Tubing

General Information	1
Determining Required Length	1
Uncoiling and Straightening	2
Tracer Connections	2
Bending	2
Installation and Support	3

Preinsulated Tubing

Center Line Tool	3
Heat-Shrink End Seal Boot Installation	4
Heat-Shrink Entry Seal Boot Installation	4
Silicone Sealant Installation	5
Jacket Patch Kit Installation	6
Power Connection Installation	7
Temperature Sensor Installation	7

General Information

Keep the tubing bundle and insulation sealed during storage, handling, and installation by taping a plastic bag around the exposed end or using a heat shrink boot.

 **Caution**
Never allow insulation to get wet.

Determining Required Length

1. Determine the length of tubing required.
2. Allow at least 12 in. (305 mm) of straight tubing before connecting to fittings.
3. For steam-traced tubing bundles, add enough length to connect the tracer to the supply connection and to the return system.
4. For electric-traced tubing bundles, add enough length to connect the power supply. Include 6 in. (152 mm) for inside the junction box. Include enough length of tracer to heat any other desired devices at the end of the bundle.



Uncoiling and Straightening

Method 1: Unroll the coil on the floor or other flat surface. Straighten by hand and remove any bows.



Method 2: Use a second smaller spool to straighten the product as it is taken off of the larger shipping spool.

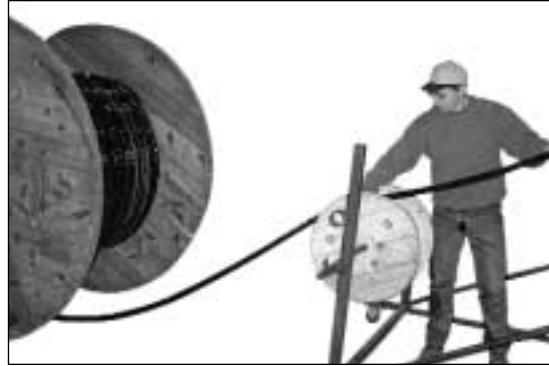

Tracer Connections

Electric tracer kits must be connected and terminated using approved power connection and termination kits.

Bending

Bend the tubing using a bundle bending tool (Fig. 1) or a mandrel such as a small spool (Fig. 2) with a radius of at least 8 in. (203 mm). If the bundle is oval in shape, make the bend with the wide side of the bundle against the tool or mandrel (Fig. 3).

Note: A bundle bending tool with a 12 in. (305 mm) radius must be used when the bundle has any of these characteristics:

- The bundle contains two or more 3/4 in. tubes.
- The smallest bundle dimension is > 1 3/4 in.
- The bundle contains a tube > or = to 1 in.O.D.

When using a bundle bending tool:

1. Place the hook around the bundle towards the end of the bundle that you need to move during the bend (Fig. 3).
2. Rotate the handle towards the stationary end of the bundle until the desired bend is achieved. If a bend greater than 90° is required, reposition the bending tool and make additional bends.

To make a lateral bend (Fig. 4):

1. Make the initial bend (Fig. 5).
2. Twist the bundle (90° maximum), and make the other bend (Fig. 6).



Fig. 1



Fig. 2



Fig. 3



Fig. 4



Fig. 5



Fig. 6

Bundle Bending Tool Ordering Information

Bundled Tubing Bend Radius	Bending Tool Ordering Number
8 in. (305 mm)	MS-BBT
12 in. (305 mm)	MS-BBT-12

Installation and Support

- To permanently install the tubing, remove temporary end seals and install the heat-shrink boot. See **Heat-Shrink End Seal Boot Installation for Preinsulated Tubing Bundles**, page 4.
- Route tubing along existing structures, such as columns and beams, to provide support.
- Support jacketed tubing as you would bare tubing, except use a support clamp 1/8 in. (2 or 3 mm) larger than the tube size.
- Support tubing every 6 ft (1.8 m) for horizontal runs, and every 15 ft (4.6 m) for vertical runs.
- Supports and hangers must have a large surface area and be designed so they cannot be overtightened to crush the jacketed tubing.
- Do not use U-bolts as supports.
- Tubing may be strapped into an angle iron for support. Place the tubing in an angle iron that is 1/2 in. (12.7 mm) larger than the widest dimension of the bundle, and secure it with metal or plastic straps.



For information about tube supports, see the *Swagelok Tube Supports* catalog.

Center Line Tool for Preinsulated Tubing Bundles

1. Cut the jacket and insulation, and remove to expose process and tracer tubes.
2. Insert the tube bundle through the seal boot.
2. Unscrew center nut and remove center bend shoe.
3. Insert tube bundle.
4. Gently bend tubes against the outside shoes.
5. Install center bend shoe and tighten center nut.
6. Bend tubes against center shoe until tubes are parallel.
7. Repeat step 2, and remove tubing bundle from tool.
8. Seal bundle ends. See **Heat-Shrink End Seal Boot Installation for Preinsulated Tubing Bundles** or **Heat-Shrink Entry Seal Boot Installation for Preinsulated Tubing Bundles**, page 4.

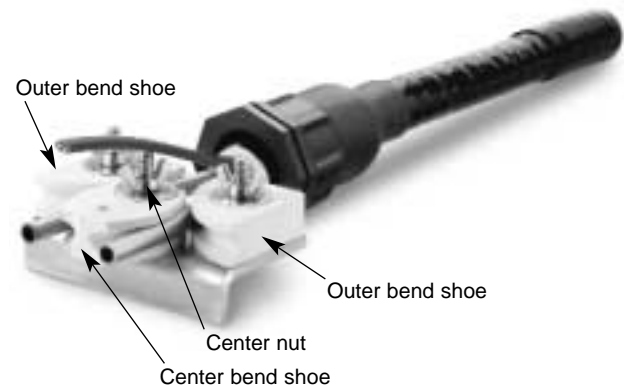

Heat-Shrink End Seal Boot Installation for Preinsulated Tubing

1. Cut back the insulation and jacket, leaving at least 12 in. (305 mm) of tubing exposed.
2. Slip the heat-shrink boot over the end of the tubing. If more than one tube is present, spread the tubes apart far enough to fit each tube into the legs on the end of the boot. Do not nick or cut the boot.

Note: Bend the process tubes to the correct instrument connection centers before shrinking the boot. This may be accomplished by using a tube bender or the center line tool.



3. Use a heat gun to shrink the boot over the tubing. Move the heat source back and forth over the boot, applying heat evenly. Once the boot has assumed the shape of the tubing, stop applying heat. Further heating will not make the boot shrink any more tightly.

Note: If the boot does not assume the shape of the tubing, pinch the boot with pliers while hot and hold until cool to reduce the leg diameter.

Warning
Do not overheat tubing when applying a heat-shrink boot to a product with plastic tubing. Excessive heat could damage the tubing.

4. Cut the tubing and / or the tracer to the length required for installation.

Heat-Shrink Entry Seal Boot Installation Kit for Preinsulated Tubing Bundles

Kit Contents

- Threaded connector
- O-ring
- Shrinkable boot

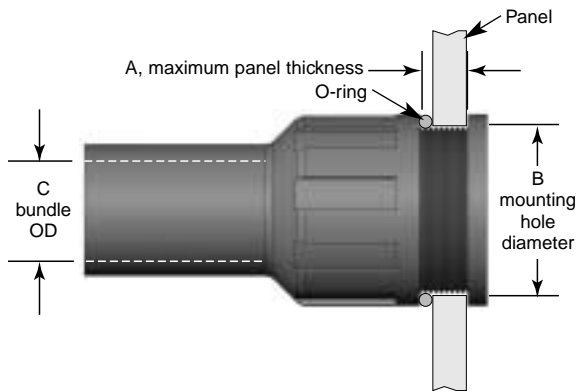

1. Place the threaded connector end into the pre-cut hole in an enclosure so the flanged end is on the inside of the enclosure.
2. Place the O-ring over the threaded end and position against outside of enclosure.
3. Screw the shrinkable boot onto the connector, and tighten using a spanner wrench.
4. Insert the insulated tubing into the shrinkable boot opening and make the necessary connections in the enclosure.

5. Use a heat gun to shrink the boot over the tubing. Move the heat source back and forth over the boot, applying heat evenly. Once the boot has assumed the shape of the tubing, discontinue heat application. Further heating will not make the boot shrink tighter.

Note: If the boot does not assume the shape of the tubing, pinch the boot with pliers while hot and hold until cool to reduce the leg diameter.

Warning
Do not overheat tubing when applying a heat-shrink boot to a product with plastic tubing. Excessive heat could damage the tubing.

Ordering Number	Dimensions, in. (mm)		
	A	B	C
MS-HSS-4-KIT	0.50 (12.7)	2.00 (50.8)	0.75 to 1.60 (19.0 to 40.6)
MS-HSS-4S-KIT	1.00 (25.4)	2.38 (60.5)	0.75 to 2.10 (19.0 to 53.3)
MS-HSS-5-KIT		3.50 (88.9)	1.43 to 2.75 (36.3 to 69.8)
MS-HSS-6X-KIT		4.50 (114)	1.50 to 3.50 (38.1 to 88.9)

Silicone Sealant Installation for Preinsulated Tubing Bundles

⚠ Caution
Seal insulation ends to prevent contamination of the insulation.

1. Cut the jacket square and remove insulation, leaving the desired length of tubing exposed.
2. Bend the process tubing to the desired position.
3. Cut and remove the insulation back under the jacket about 3/8 in. (9.5 mm).

⚠ Do not push back the insulation. It must be removed as indicated.

4. Fill the cavity end with silicone sealant, making sure that all exposed insulation is sealed.

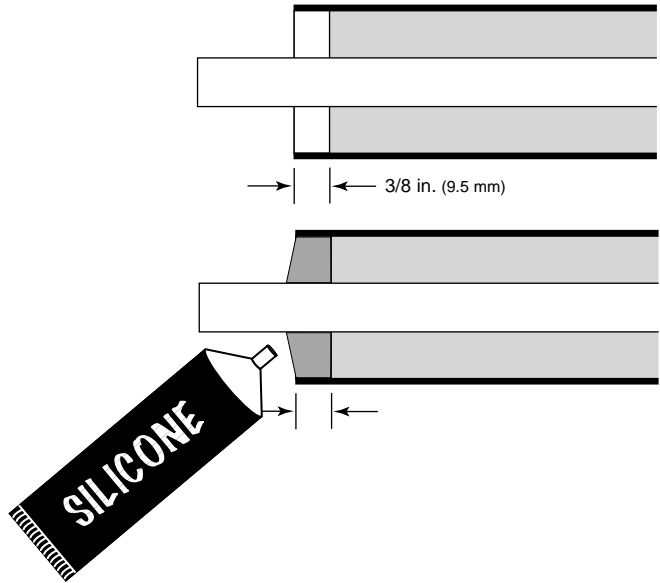

Jacket Patch Kit Installation for Preinsulated Tubing Bundles

Kit Contents

- Thermal insulation
- Self-sealing black rubber patch
- Fiberglass tape

To install the jacket patch kit at a splice:

1. Cut the jacket square and remove insulation, leaving desired length of tubing exposed on both pieces (Fig. 1).
2. Use a Swagelok tube fitting to connect the tubes (Fig. 2).
3. Wrap the area with thermal insulation until it is built up to the outside diameter of the jacket (Fig. 3). Use the fiberglass tape to hold the insulation in place.
4. Cut the self-sealing black rubber patch so that it extends over the pre-existing tubing bundle jackets by 1 in. (25.4 mm) on each side (Fig. 4).
5. Remove the protective wax paper backing, and wrap the patch around the area to be patched. Leave the clear protective layer in place and facing out.
6. Overlap the edges of the patch by at least 1/2 in. (12.7 mm) and press the patch into place (Fig. 4).
7. Use the fiberglass tape to hold the patch in place and prevent separation of the seams until it cures.

To install the jacket patch kit at a tubing end:

1. Wrap insulation around the tubes and fittings until the diameter is built up to equal the outside diameter of the jacket (Fig. 5).
2. Cut the patch material to extend over the jacket by 1 in. (25.4 mm) and beyond the insulation on the individual tubes by 3/8 in. (9.5 mm) (Fig. 6).
3. Remove the protective wax paper backing, and wrap the patch around the area to be patched. Leave the clear protective layer in place and facing out.
4. Overlap the edges of the patch by at least 1/2 in. (12.7 mm), and press the patch into place.
5. Use the fiberglass tape to hold the patch in place and prevent separation of the seams.
6. Fill the cavity end with a sealant, such as silicone sealant, making sure that all exposed insulation is protected (Fig. 7).

Fig. 1

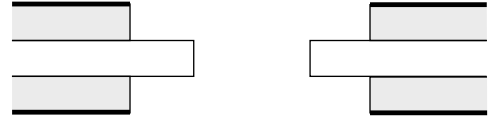

Fig. 2

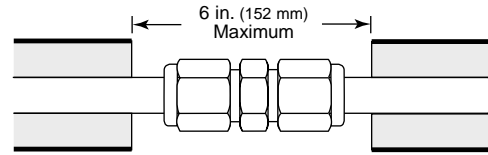

Fig. 3

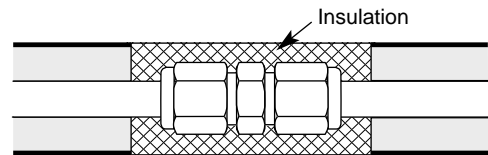

Fig. 4

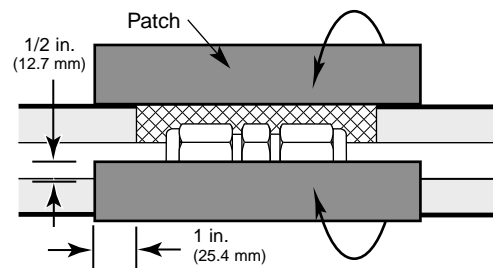

Fig. 5

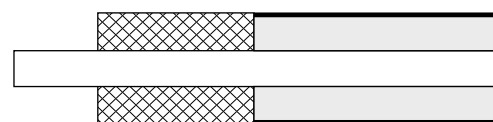

Fig. 6

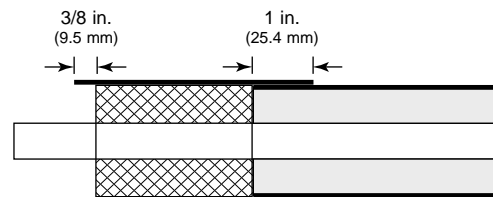
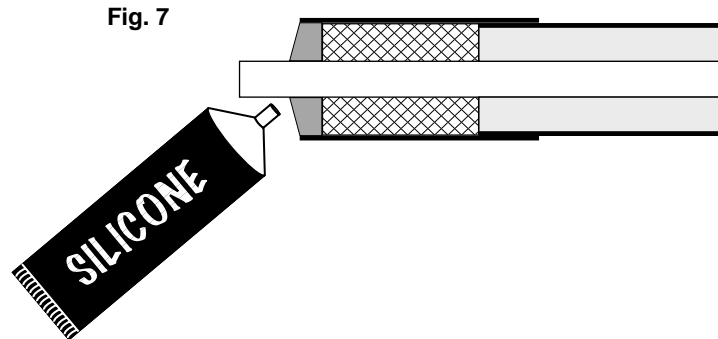

Fig. 7



Power Connection Installation for Preinsulated Tubing Bundles

Kit Contents

- Junction box and cover
- 24 in. (610 mm) convoluted tubing
- Mounting bracket
- 2 mounting straps
- Connection kit



To mount bundle:

1. Cut the jacket and insulation to expose the process and tracer tubes to the length required to connect to the power location.
2. Seal the end of the bundle with a heat-shrink end seal boot or entry seal boot. See **Heat-Shrink End Seal Boot Installation for Preinsulated Tubing** or **Heat-Shrink Entry Seal Boot Installation Kit for Preinsulated Tubing Bundles**, page 4.
3. Cut the process tubing to length and make connections.
4. See the manufacturer's instructions for installing the connection kit.

⚠ Caution

Electric Traced Systems

Consult installation instructions received with the kit. You may be required to make connections and terminations at a particular point on the tracer. If so, these points will need to be located prior to cutting the bundle to its final length. Failure to properly install the electric tracer can lead to excessive heating, tracer failure, and damage to the tubing bundle.

Temperature Sensor Installation for Preinsulated Tubing Bundles

The purpose of this instruction is to provide general guidance in the installation of a temperature sensing thermostat, an RTD, or thermocouple. Each thermostat is different and specific instructions may vary; see any additional instructions received with the specific product.

⚠ Caution

The sensor should be in contact with the process tubes only and not the tracer. Contact with the tracer could cause a false reading.

1. Determine a suitable mounting location for the thermostat housing, and route the capillary along the bundle.

⚠ Caution

Do not place near heater or near process connection in an enclosure. Doing so will cause the thermostat to register an inaccurate temperature.

2. Measure the sensor length and add an additional 2 in. (50.8 mm). This will be your slit length.
3. Slit the bundle lengthwise as determined in step 2, ensuring that the slit goes through the insulation and polyester film, opposite the tracer, where the sensor will be placed.
4. Insert the sensor into the bundle. The sensor should touch the process tubes only.

5. Once the sensor is in place, hold the slit area together and place fiberglass tape every 1 1/2 in. (38.1 mm) over the slit area.
6. Secure the capillary to the bundle with the fiberglass tape at least 2 in. (50.8 mm) from the end of the slit.
7. Apply a bead of silicone sealant along each side of the capillary.
8. Using a jacket patch kit, wrap the bundle with the rubber patch where the slit was made previously. See **Heat-Shrink Entry Seal Boot Installation Kit for Preinsulated Tubing Bundles**, page 4, steps 4 to 7.
Note: The rubber patch should extend 2 in. (50.8 mm) past the slit on each side.

Similar techniques can be used to install other sensing devices. See any additional instructions provided by the device manufacturer.